



# Village of Hawthorn Woods

2 Lagoon Drive  
Hawthorn Woods, Illinois 60047  
Web Page: [www.vhw.org](http://www.vhw.org)

Phone: (847) 438-5500  
Fax: (847) 438-1459

**Keith L. Hunt**  
**Village Mayor**

---

## VILLAGE OF HAWTHORN WOODS INFORMATION

[www.vhw.org](http://www.vhw.org)

July 2008

The Village was incorporated in 1958 and is located approximately 40 miles northwest of downtown Chicago. The Village is bordered generally by the Village of Long Grove on the east and southeast, the Village of Kildeer on the south, the Village of Lake Zurich on the southwest and the Village of North Barrington on the west. North of the Village is unincorporated Lake County.

The Village had a Special Census 2007 population of 7,500, which is an increase from the Village's Census 2000 population of 6,002. The Village has an area of approximately 22.5 square miles and is predominantly a residential community, with over 2,700 homes set generally on one-acre parcels.

### **VILLAGE GOVERNMENT AND SERVICES**

The Village is a non-home rule unit of government and is governed by a President and a six-member Board of Trustees elected at large for four-year terms. The Village Administrator handles day-to-day operations and is appointed by the President and the Board of Trustees. The Village provides public safety, streets and bridges, parks and recreation, public improvement, planning and zoning, building review, and general administrative services.

The Village maintains nine parks with over 80 acres of parkland. The parkland and facilities provide residents with recreational opportunities, including: fields and facilities for sports, fishing, nature trails, ice skating, sledding and playgrounds.

### **SCHOOLS AND OTHER SERVICE PROVIDERS TO VILLAGE RESIDENTS**

Unit Community School Districts Number 79, 95 and 96 serve Village residents, as well as High School Districts Number 120 and 125. Five private schools also provide K-12 education to Village residents. The Lake Zurich Fire Department, the Long Grove Fire Protection District, Countryside Fire Protection District and the Wauconda Fire Protection District provide fire protection to Village residents. Library services are provided to Village residents through the Ela Area Library, located in Lake Zurich and the Fremont Library located in Mundelein.

Non-governmental service providers to Village residents include: Comcast (cable services), Commonwealth Edison (electricity), Waste Management (garbage disposal), and Nicor Gas (natural gas).

### **TRANSPORTATION**

Interstate 94 is located approximately 10 miles east of the Village and Interstate 90 is located approximately 15 miles south of the Village. Other principal highways include State Highway 22 (Lake Zurich Road) and Federal Highway 12 (Rand Road). RTA, Pace and Metra transportation services are also available. By car, O'Hare Airport is approximately 30 minutes from the Village and Midway Airport is approximately one hour from the Village.

## **VILLAGE OFFICES**

[www.vhw.org](http://www.vhw.org)

### **Administrator's Office**

2 Lagoon Drive  
Monday - Friday 8:30 a.m. to 5:00 p.m.  
(847) 540-5222

Village Administrator -  
Asst. Village Administrator - **Donna Lobaito**

### **Building Department**

2 Lagoon Drive  
Monday - Friday, 8:30am to 5:00pm  
(847) 847-3527

Building Dept. - **Christina Luburich**

### **Village Clerk's Office**

2 Lagoon Drive  
Monday - Friday, 8:30am to 5:00pm  
(847) 438-5500

### **Public Works Department**

35 Old McHenry Road  
Monday - Friday, 7:00 a.m. to 3:30 p.m.  
(847) 438-5500

Public Works Director - **Jim Maiworm**

### **Police Department**

2 Lagoon Drive  
**Monday - Friday 8:30 a.m. to 4:30 p.m.**  
(847) 438-9050  
In case of an emergency call, **9-1-1**

**Chief of Police - Jennifer Paulus**  
Records Supervisor - **Jan Filenko**

## **SERVICES AVAILABLE**

Applications for:

- Building Permit
- Barn Rental
- Business License
- Contractor's License
- Dog Tags (For the Village, not the County)
- Liquor License
- Motorcycle Tags (\$20)
- Motor Vehicle Stickers (For the Village, \$30)
- Notary Public Services (No fee)
- Special Use Permit
- Tree Removal Permit (No fee)
- Temporary Handicap Placards (No fee)
- Variance Permit
- Voter Registration (No fee)
- Yard Waste Tags (\$3.00)

## **GOVERNMENT SERVICES**

Fire protection is provided by the Lake Zurich Fire Department, Long Grove Fire Protection District, Countryside Fire Protection District and Wauconda Fire Protection District.

Police protection is provided by the Hawthorn Woods Police Department and Police Chief.

### **HANDY TELEPHONE NUMBERS**

Aqua Illinois	1-800-851-1305	<a href="http://www.aquaamerica.com">www.aquaamerica.com</a>
Comcast Cable Services	1-866-594-1234	<a href="http://www.comcast.com">www.comcast.com</a>
Commonwealth Edison	1-866-639-3532	<a href="http://www.ucm.com/comed/overview/ecr_overview.shtml">http://www.ucm.com/comed/overview/ecr_overview.shtml</a>
Drivers License Bureau Libertyville DMV 342 Peterson Road Libertyville, IL	1-847-362-7171	
Ela Township Tax Assessor	1-847-438-8370	
Foglia YMCA	1-847-438-5300	<a href="http://fogliaymca.org/">http://fogliaymca.org/</a>
Fremont Township Tax Assessor	1-847-222-2846	
Ela Area Library 275 Mohawk Trail Lake Zurich, IL 60047	1-847-438-3433	<a href="http://www.eapl.org">www.eapl.org</a>
Fremont Public Library 1170 N. Midlothian Rd. Mundelein, IL 60060	1-847-566-0204	<a href="http://www.fpld.alibrary.com">www.fpld.alibrary.com</a>
Garbage Disposal/Yard Waste Waste Management	1-800-796-9696	<a href="http://www.wm.com/">www.wm.com/</a>
Hawthorn Woods Women's Club	1-847-438-0723	<a href="http://www.hwmc.org">www.hwmc.org</a>
Nicor Gas	1-888-642-6748	<a href="http://www.nicor.com">www.nicor.com</a>
Lake Zurich Post Office 380 Surryse Lake Zurich	1-800-275-8777	
Mundelein Post Office 435 E. Hawley Mundelein	1-800-275-8777	
Secretary of State	1-800-252-8980	<a href="http://www.sos.state.il.us/">http://www.sos.state.il.us/</a>
ATT	1-800-244-4444	<a href="http://www.ATT.com">www.ATT.com</a>

### **Important Information**

#### **Alarm Ordinance**

Each residence is allowed three (3) false alarms in any calendar year. False alarms, in excess of three (3), are fined \$50.00 for the first violation, \$75.00 for the second violation and \$100.00 for each subsequent violation. A false alarm is defined as an alarm “not triggered by an unauthorized intrusion or other condition reasonably requiring police response.”

### **Animals – Pets**

A residence may not have more than three (3) dogs, three (3) cats, three (3) other domesticated animals, or any combination thereof.

Dogs, when on any public street, walk, parkway, or public area shall be on a leash no longer than eight feet (8') in length. In public parks dogs and cats must be leashed.

Dogs must have a valid Village dog license. To obtain a license, the owner must show proof of a current rabies inoculation.

### **Animals – Wild**

The Lake County Community Health Environmental Health Services  
(847) 949-9925

McHenry County Conservation District Wildlife Center  
(815) 728-8307

A-B-C Humane Wildlife Control  
(847) 870-7175  
[www.abcwildlife.com](http://www.abcwildlife.com)

Barn swallow, A Wild Bird Concern  
Rehabilitation of injured and orphaned owls, hawks & falcons  
(847) 487-3606  
[www.barnswallow.net](http://www.barnswallow.net)

### **Barn Rental**

The community room in the Barn is available to rent for social functions. The capacity is 175 persons for meetings/business functions and 100 for entertainment functions. The barn usage fee is \$150.00(residents) \$250.00 (non-residents), with a \$100.00 cleaning deposit and \$200.00 emergency services deposit. These fees are due upon submittal of application. A Certificate of Insurance is required.

### **Building Permits**

Building permits are required for most improvements of remodeling involving structural changes, additions, plumbing or electrical changes over \$1,000. In addition, certain improvements requiring inspections such as patios or brick light posts may also need a building permit. There is a distinction between maintenance and remodeling – please call the Building Department before your project to determine if you will be required to have a permit.

### **Building Setbacks (R-1 – Single Family)**

Front = 30 Feet (Cul-de-Sac = 50')    Sides = 20 Feet    Back = 50 Feet

### **Business Licenses**

A license is required when any person, by himself or through an agent, employee or partner is held forth as being engaged in the business, or if he solicits patronage therefore, actively or passively.

### **Contractor's Licenses**

Effective June 30, 2005, Ordinance No. 1128-05 will be in effect requiring all contractors and subcontractors doing business in the Village of Hawthorn Woods to be licensed by the Village. The term “contractor” and “subcontractor” shall include, but not be limited to: Any person or company who undertakes to construct, alter, improve, install, repair, remodel, rehabilitate, renovate or move any land, house, building or other structure (of any kind or nature, whether residential or not) or any fixture or any

other item that is located on or in the ground and/or attached to something that is located on or in the ground.

### **Covenants**

Many subdivisions have covenants. Covenants can be found on the Village website [www.vhw.org](http://www.vhw.org). If your subdivision is not listed they have not provided the Village with an updated version.

### **Curfew**

For persons under the age of 17 years, the curfew is as follows:

11:00 p.m.     Sunday through Thursday  
12:00 p.m.     Friday and Saturday

### **Dog Run**

Maximum area not to exceed 200 square feet and shall not be wider than 15'. Maximum length of any side of dog run shall not exceed 20'; minimum height 4'; maximum height 6'. Dog run can be used for no other purpose and shall not be visible from the street. **A permit is required.**

### **Driveways**

A permit is required for the replacement of driveways. If you choose to install a concrete or brick driveway a letter of indemnification must be signed and recorded with Lake County Recorder's Office. The Village will not replace any damage done to driveways made of special materials.

### **Fences**

**All Fences are prohibited.** A fence is defined as any barrier or enclosure and includes living fences made of hedges or trees. The only exception to the fence ordinance is a tennis court and a swimming pool. A fence around a pool is mandatory.

### **House Numbering**

House numbers in Arabic numerals at least four inches (4") high must be placed on each residence in a location and manner so as to be visible from the street to persons approaching from either direction.

### **House Watch**

If you are leaving for an extended trip or vacation, the Police will periodically check your home, if no one is staying in the building. You may call the Police Department at 847-438-9050, during regular business hours to request the check or pick up a request form in the lobby of the Police Department.

### **Open Burning**

Open Burning of landscape waste material is allowed from April 1<sup>st</sup> to May 15<sup>th</sup> and from October 15<sup>th</sup> to November 30<sup>th</sup>, on Wednesdays and Saturdays between the hours of 9:00 a.m. and 6:00 p.m. on private property only.

### **Overnight Parking / Street Parking**

No parking overnight is allowed on the street from 2:00 a.m. to 6:00 a.m. Call the police department for special situations. Parking on the street is permitted only on the odd side with all four wheels on the paved portion of the roadway.

### **Parental Responsibility**

Parents are held financially responsible for anything their children are involved in where the laws are broken. Parents are also held responsible for "beer parties" for underage drinkers in their homes.

### **Parks**

Village parks are for the enjoyment of everyone. For locations of all Village parks, please visit our website at [www.vhw.org](http://www.vhw.org) or come into the Clerk's Office for a copy.

### **Right-of-Way**

Individual property lines do not extend to the road's edge, although property owners normally maintain this area to enhance the appearance of their homes. Only mailboxes are permitted in the right-of-way. Major re-grading or installation of drain tiles is only allowed by permit.

#### Roof Replacement

The Village requires that a permit be obtained prior to the installation or replacement of any roof.

#### Sheds

**Shed are prohibited** (See Ordinance 381-87)

#### Snowmobiles, Minibikes

It is **unlawful**:

- Ⓢ to operate any snowmobile within the Village between the hours of twelve o'clock (12:00) midnight and eight o'clock (8:00) a.m., Monday through Friday, and between the hours of two o'clock (2:00) a.m. and eight o'clock (8:00) a.m., Saturday
- Ⓢ to operate any snowmobile on any Village highway or street at any time
- Ⓢ to operate any snowmobile within 100 feet of any area cleared or designated for skating purposes, sledding or tobogganing purposes, or other winter activities
- Ⓢ to operate any snowmobile on any public property, including but not limited to Village owned property, including park property without the written consent of the owner thereof

#### Satellite Dishes, Antennas

Within certain restrictions, satellite (earth stations) dishes (18 inch dish doesn't require a permit) and amateur radio antennas may be allowed with a Special Use Permit. An application for the Architectural Review Commission, fee, and attendance at the Public Hearing is required. See the Village Administrator to apply.

#### Swimming Pool

Only in-ground pools are allowed. A fence is mandatory. See the Village Clerk's Office/Building Department for application and guidelines.

#### Trailers and RV's

Camping trailers, motor homes, boats, boat trailers, snowmobiles, snowmobile trailers, personal watercraft trailers and motorcycle trailers may be parked in driveways only between the hours of one minute after twelve o'clock (12:01 a.m.) each Friday through fifty nine minutes after eleven o'clock (11:59) p.m. each Monday.

Permits can be obtained for parking outside for a 5-day period for maintenance or loading/unloading. Two (non-consecutive) permits are allowed per lot each year.

#### Tree Ordinance

Before any tree may be removed, for any reason, the Village must be notified. A Permit is required. You can obtain an application in the Village Clerk's office.

#### Vehicle Stickers

All motor vehicles registered to a Village of Hawthorn Woods address must have a current Village vehicle sticker displayed on the vehicle. If you have a child at college and their vehicle is registered in Hawthorn Woods they must still purchase a vehicle sticker.

Vehicle stickers may be purchased at the Village Hall. **New residents have 30 days from the date of move-in to obtain a sticker.** Senior citizens age 65 and over may purchase their first two (2) stickers for a reduced fee. The Village licensing year is from May 1<sup>st</sup> to April 30<sup>th</sup> of the following year.

---

## AREA SCHOOLS

**DISTRICT 79**

Fremont Middle School 847-566-9384  
28855 N. Fremont Central Road  
Mundelein

Fremont Elementary School 847-837-0437  
28908 N. Fremont Center Road  
Mundelein

Mundelein High School 847-949-2200  
1350 W. Hawley St.  
Mundelein

Prairie Crossing Charter School (PCCS) 847-543-9722  
Grayslake

**DISTRICT 95**

Administrative Office 847-438-2831  
400 S. Old Rand Rd  
Lake Zurich

Isaac Fox School 847-540-7020  
May Whitney Elementary 847-438-2351  
Quentin Elementary 847-438-2420  
Sarah Adams Elementary 847-438-5986  
Seth Paine Elementary 847-438-2163  
Spencer Loomis (1 Hubbard Avenue) 847-719-3300  
Lake Zurich Jr. High 847-438-2361  
Lake Zurich High 847-438-5155

**DISTRICT 96 – LONG GROVE**

Kildeer Countryside Elementary 847-634-3243  
Twin Grove High School 847-821-8946

**DISTRICT 125**

Adlai E. Stevenson High 847-634-4000  
1 Stevenson Drive  
Lincolnshire

**PRIVATE SCHOOLS**

Carmel High 847-566-3000  
Countryside Center 847-438-8855  
St. Francis de Sales (Grade) 847-438-7921  
St. Mary's (Grade) 847-223-4021  
St. Matthew Lutheran (Grade) 847-438-6103  
Transfiguration School (Grade) 847-526-6311

**MAILBOX REGULATIONS**

- ✓ The address identified by numerals not less than one inch high must be placed on the side of the box from which the carrier approaches for single mailboxes.
- ✓ Residents are responsible for the removal of snow, debris or any obstructions that will prevent the carrier from delivering their mail to their box without leaving the vehicle.
- ✓ Mailboxes must be securely attached to its post to prevent separation if struck.

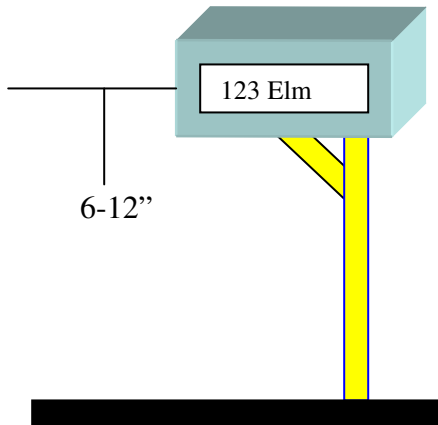

Front of mailbox must be 6 to 12 inches back from edge of roadway

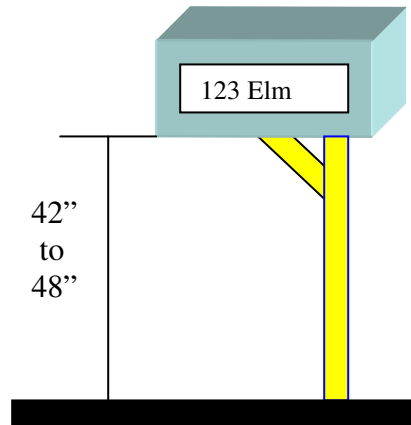

Bottom of mailbox must be 42 to 48 inches from roadway surface